

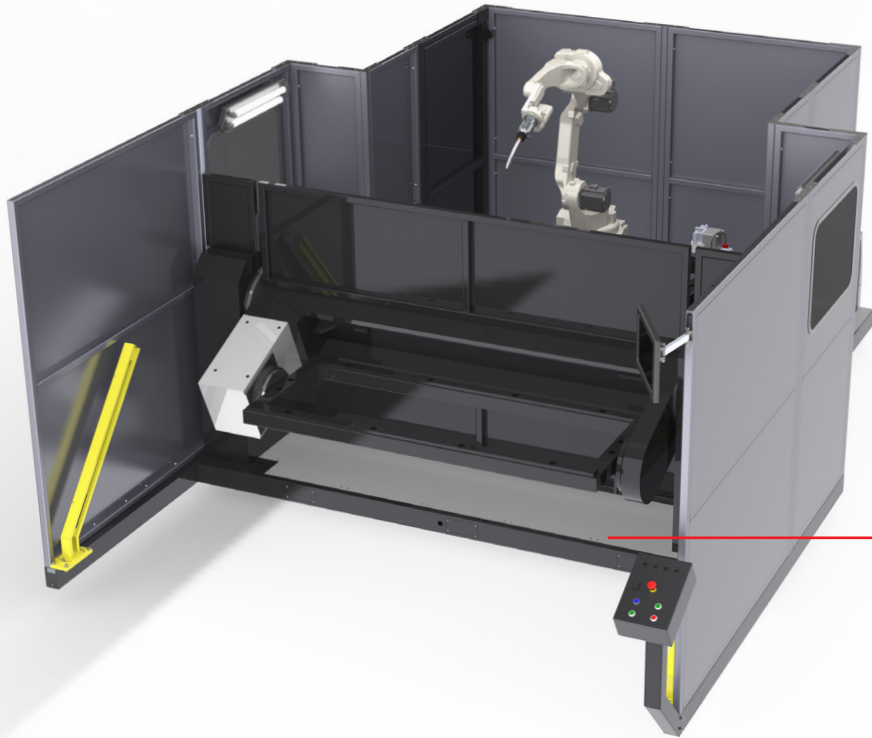

Ready to Weld with Maintenance Door



Single point of supplying

Single base with welding table

Optimized working area

Ideal for medium and high productivity



The **Advantage REVOCELL H** cell is the ideal cell for those seeking productivity, designed for medium to high production.

The cell has 02 (two) workstations with table, and has a fast devices exchanging system.

Included in package



+



+



Workstation dimensions	750 x 2000 mm
Capacity	1000 kg
Maximum current for power source	63A
Maximum current for controller and robot	16A
Feeding	380V Trifásico
Dimensions	3500 x 5650 x 2120 mm
Weight	5500 kg
Power	26 kVA
Pressure	6 BAR
Air Flow	8,8 L/s
Size in m²	18,8m ²

Measurements

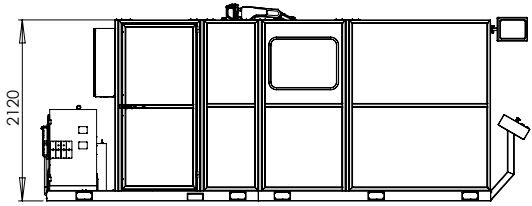

Front

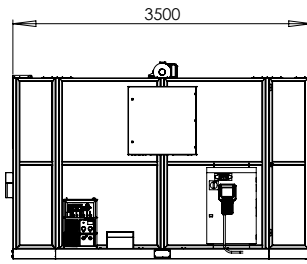

Side

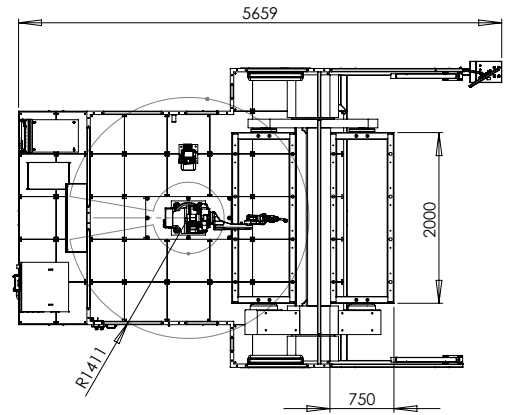

Working Area

Standard Components



OTC Robot



Power Source



SU477 Robotic Welding Torch

Optionals

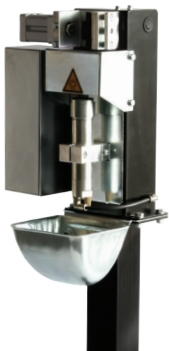

Cleaning Unit

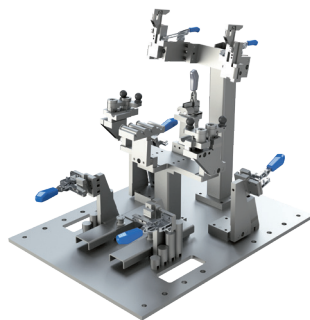

Tooling



Neuron-S Adapt